

KOALA 370 AF



ATP



Refrigerated container for the transport of food/pharmaceutical products at a controlled temperature

- Available in versions:
 - AF: temperature adjustment range: from **-18°C e +10°C**;
 - AFH: with heating kit and temperature adjustment range: from **-18°C e +40°C**.
- Insulation offered by container walls ensures that the temperature maintenance is guaranteed with a minimum number of ignitions of the cooling unit; this contributes limiting energy consumption.
- Available with static cooling unit, which ensures reduced electrical consumption, or ventilated, which ensures a greater speed of achievement and temperature uniformity inside the container.
- Cooling unit is triggered when inner temperature is higher than the temperature set with the programmable digital thermostat. This allows to maintain a constant temperature even in case of very high external temperatures.
- In the AFH versions, the heating unit is triggered when inner temperature is lower than the temperature set with the programmable digital thermostat. This allows to maintain a constant temperature even in case of very low external temperatures.
- Total compliance with the cold chain at all stages of transport.
- It can be transported using conventional vehicles: it allows to simultaneously transport chilled, frozen and ambient temperature products using a single non-insulated vehicle.
- Equipped with a low consumption fridge unit.
- It can be powered at 230Vac, using normal mains power.
- It can be powered at 12Vdc, depending on the model, directly or by inverter, it can be connected to the battery (or auxiliary battery) of the vehicle.
- Manufactured using the rotational moulding technology: mono-block container and door (free of sharp edges, joints and welds).
- **Fully recyclable** at the end of the operating life.









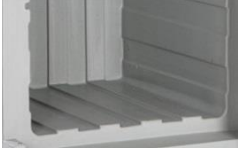

MANUFACTURING MATERIALS

Polyethylene	inner and outer walls of the container and lid; suitable for food contact	Polyurethane	insulating material between the walls of the container and of the lid; free of CFC and HCFC
Silicone	gasket	Rubber and polyamide	castors (rubber tread and polyamide core)
Galvanized steel	cooling unit frame, hinge rods, plates connecting rods hinge, castors support	Stainless steel	handling handles, locking handle, inner rod of the door
Polypropylene	hinges		

TECHNICAL CHARACTERISTICS

<p>AF Version</p>	<ul style="list-style-type: none"> • from 0°C to +10°C • from -18°C to +10°C 	<p>AFH Version</p>	<ul style="list-style-type: none"> • from 0°C to +40°C • from -18°C to +40°C
<p>+/- 0,5 °C</p>	<p>Degree of accuracy in temperature adjustment:</p> <ul style="list-style-type: none"> • +/-0,5 °C 		<p>Protection against voltage drops of the vehicle battery, in case of falling below of the limit value of 11V</p>
	<p>Equipped with three cables: for power supply to 230Vac 50-60Hz</p>		<p>For power supply to 12Vdc</p> <ul style="list-style-type: none"> • with Anderson connectors
	<p>For power supply to 12Vdc</p> <ul style="list-style-type: none"> • with Anderson terminal for connection to the Koala and with cigarette lighter plug on the other end of the cable • with Anderson terminal for connection to the Koala and fork terminals for connection to the battery of the vehicle <p>(depending on the versions, see table in technical data for detailed information)</p>		<ul style="list-style-type: none"> • Cooling unit performance guaranteed for use at ambient temperature: from +10°C to +30°C. • Container (insulated case) guaranteed for use: from -30° to +100°C
<p>GAS</p>	<p>Coolant gas:</p> <ul style="list-style-type: none"> • R134a (versions cooling unit on back and on top static 0°C +10/+40°C) (versions cooling unit on back and on top ventilated 0°C +10/+40°C) • R452A (version cooling unit on top ventilated -18°C +10/+40°C) (version cooling unit on back ventilated -18°C +10/+40°C) 		<p>Adjustment and control of the temperature with programmable digital thermostat</p>
	<p>Static versions equipped with a "roll-bond" static evaporator.</p> <p>Lower energy consumption compared to the version with ventilated cooling unit</p>		<p>In ventilated versions (available with cooling unit on back) the ventilation system ensures a greater speed of achievement and temperature uniformity inside the container.</p>
	<p>USB data logger available (on request) to record temperature data during transport</p>		<p>Hermetic compressor with electronic control unit for adjustment and control equipped with overvoltage protections</p>

TECHNICAL CHARACTERISTICS

	<p>3 seats for housing of grids positioned to 335/500/665mm from the bottom of the container. Grids available on request</p>		<p>Label holder (on request) for the identification of the content or destination. Suitable for A5 format documents</p>
	<p>Stainless steel locking handle with release button; it is prepared for the use of tamper-proof system</p>	<p>K</p>	<p>Overall heat transmission coefficient: K=0,32 W/m²K</p>
	<p>Internal grooves improving good air circulation</p>		<p>Door opens up to 270° with door retaining catch</p>
	<p>Easily removable door seal</p>		<p>Stainless steel rod with 2 hooks integrated inside the door</p>
	<p>4 rubber coated castors of 100 mm diameter (2 fixed and 2 swivel of which one equipped with brake). Support runners plate integrated in the container</p>		<p>It can be inserted: - Pallet with galvanized steel frame at 4 feet of 120 mm - 4 feet in galvanized steel h 130mm</p>
	<p>Mono-block structure, no sharp edges, joints and welds</p>		<p>Insulated with CFC and HCFC-free polyurethane foam</p>

TECHNICAL SPECIFICATIONS

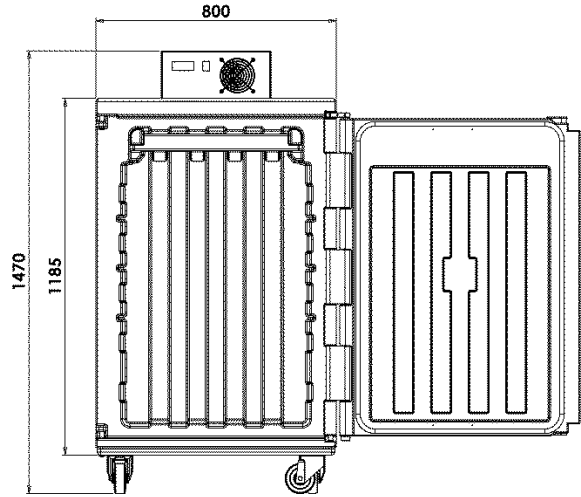
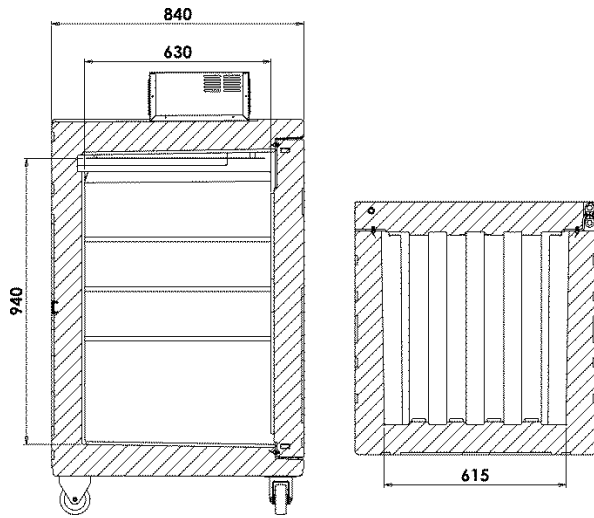

**Model with cooling unit on top positive static
code: K370AFTSDYM1, K370AFTSDZM1**

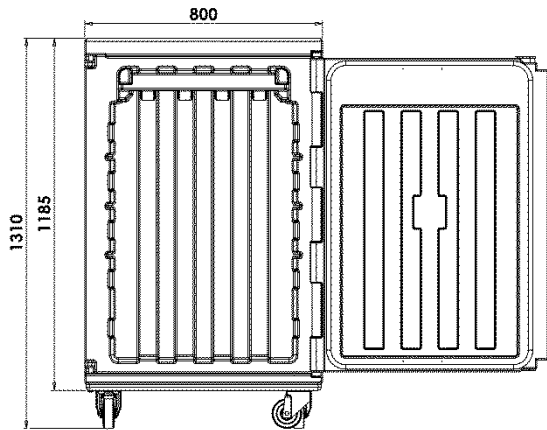
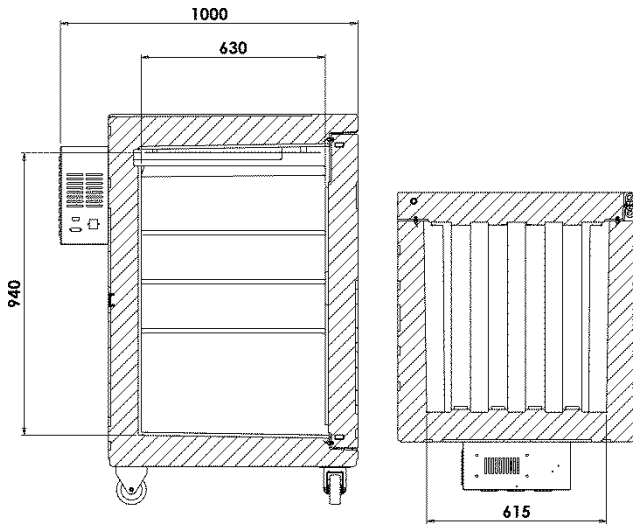

**Model with cooling unit on back positive static
code: K370AFDSDYM1, K370AFDSDZM1**

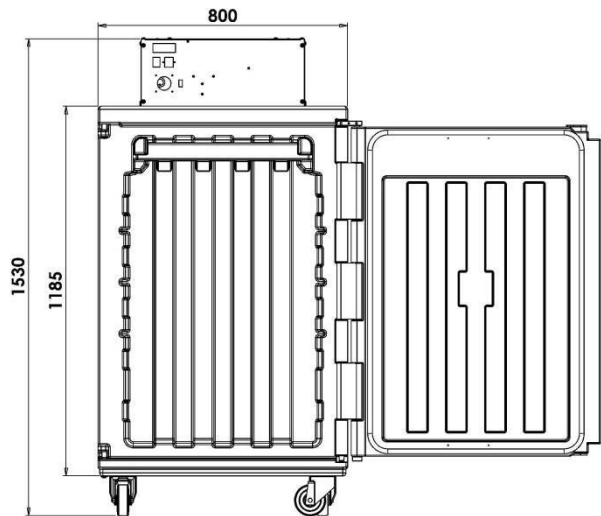
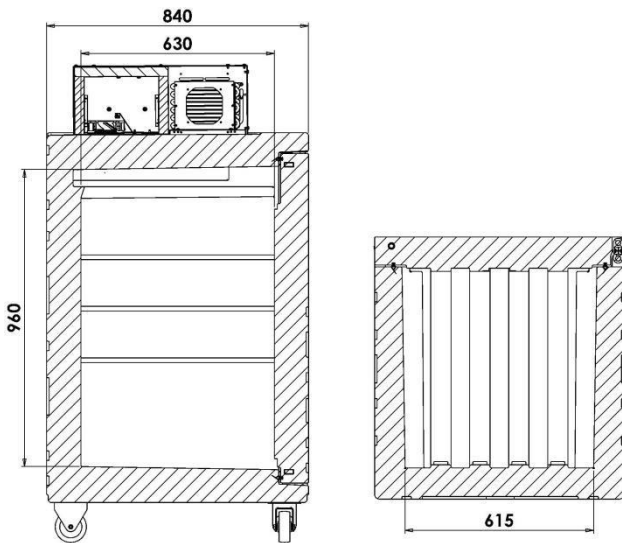

**Model with cooling unit on top ventilated
code: K370AFTVDYM1, K370AFTVDZM1**

TECHNICAL SPECIFICATIONS

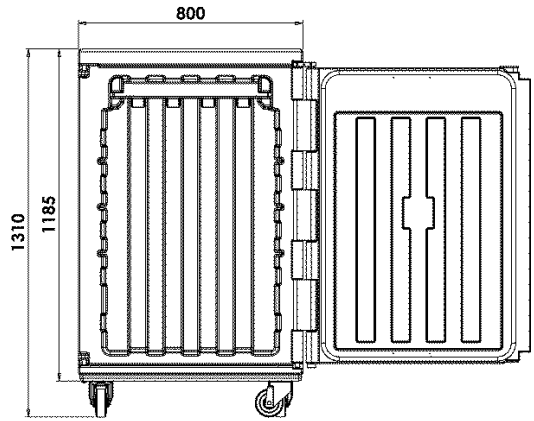
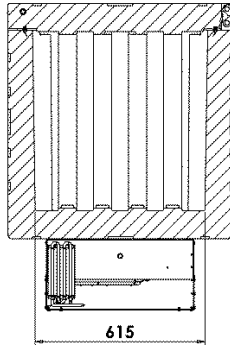
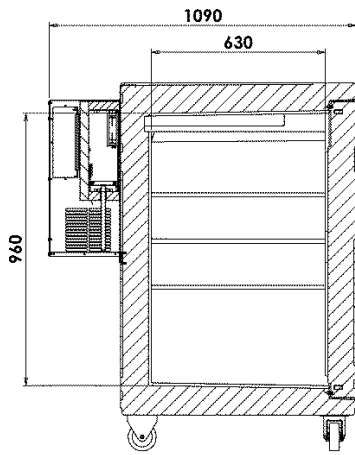

**Model with cooling unit on back positive ventilated
code: K370AFDVDYM1, K370AFDVDZM1**

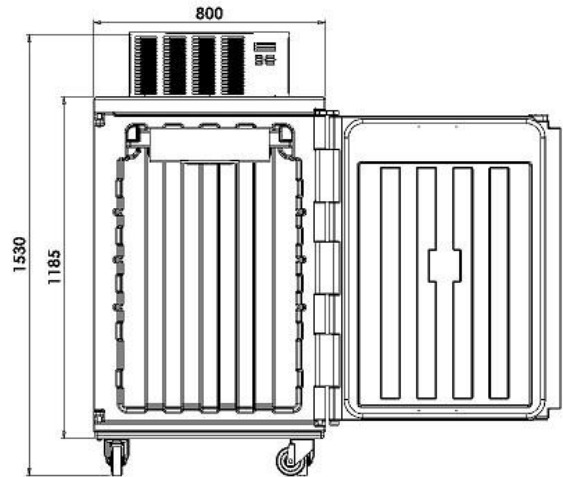
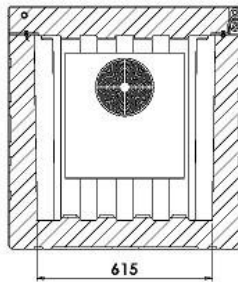
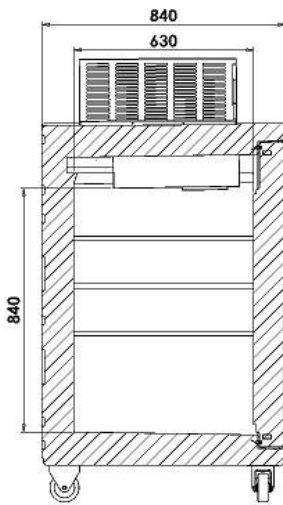

**Model with cooling unit on top negative ventilated
code: K370AFTVCYM1, K370AFTVCZM1**

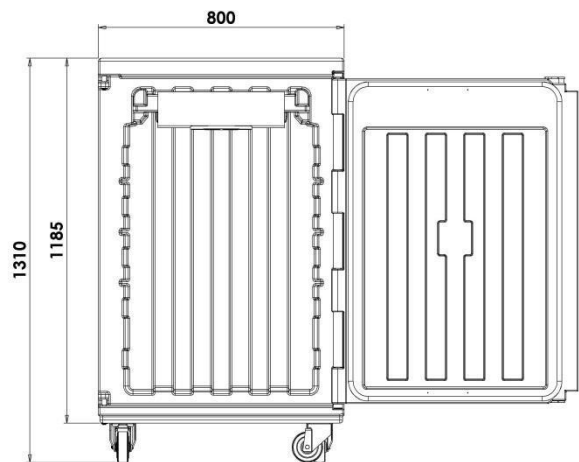
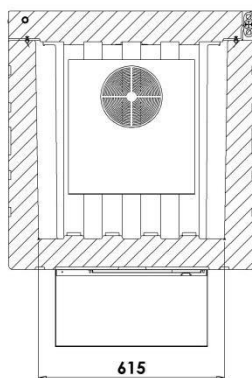
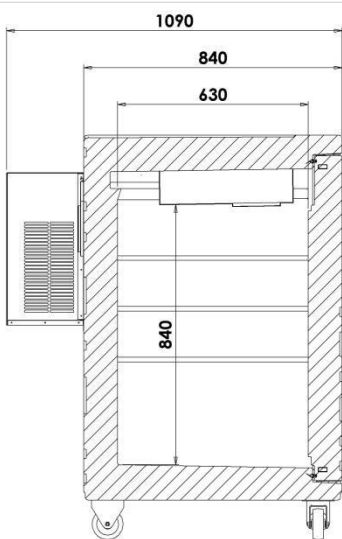

**Model with cooling unit on back negative ventilated
code: K370AFDVCYM1, K370AFDVCZM1**

Model	Code	12V Power supply Fork terminal	12V Power supply Cigarette lighter socket	Nominal absorption	Fuses
AF VERSION					
Koala 370 AF cooling unit on top static from 0°C to +10°C	K370AFTSDYM1		✓	0,62A to 230Vac 12A to 12Vdc	4A for 230Vac 25A for 12Vdc
Koala 370 AF cooling unit on back static from 0°C a +10°C	K370AFDSDYM1		✓	0,62A to 230Vac 12A to 12Vdc	4A for 230Vac 25A for 12Vdc
Koala 370 AF cooling unit on top ventilated from 0°C to +10°C	K370AFTVDYM1	✓		0,62A to 230Vac 12A a 12Vdc	4A for 230Vac 25A for 12Vdc
Koala 370 AF cooling unit on back ventilated from 0°C to +10°C	K370AFDVDYM1	✓		0,62A to 230Vac 12A to 12Vdc	4A for 230Vac 25A for 12Vdc
Koala 370 AF cooling unit on top ventilated from -18°C to +10°C	K370AFTVCYM1			2A to 230Vac	4A for 230Vac
Koala 370 AF cooling unit on back ventilated from -18°C to +10°C	K370AFDVCYM1			2A to 230Vac	4A for 230Vac
AFH VERSION (with heating kit)					
Koala 370 AFH cooling unit on top static from 0°C to +40°C	K370AFTSDZM1		✓	0,62A to 230Vac 12A to 12Vdc	4A for 230Vac 25A for 12Vdc
Koala 370 AFH cooling unit on back static from 0°C to +40°C	K370AFDSDZM1		✓	0,62A to 230Vac 12A to 12Vdc	4A for 230Vac 25A for 12Vdc
Koala 370 AFH cooling unit on top ventilated from 0°C to +40°C	K370AFTVDZM1	✓		0,62A to 230Vac 12A to 12Vdc	4A for 230Vac 25A for 12Vdc
Koala 370 AFH cooling unit on back ventilated from 0°C to +40°C	K370AFDVDZM1	✓		0,62A to 230Vac 12A to 12Vdc	4A for 230Vac 25A for 12Vdc
Koala 370 AFH cooling unit on top ventilated from -18°C to +40°C	K370AFTVCZM1			2A to 230Vac	4A for 230Vac
Koala 370 AFH cooling unit on back ventilated from -18°C to +40°C	K370AFDVCZM1			2A to 230Vac	4A for 230Vac

Model	Code	Colour	External dim. (mm)	Internal dim. (mm)	Capacity l	Weight Kg
Koala 370 AF cooling unit on top positive static	K370AFTSDYM1 K370AFTSDZM1	melange grey blue	800x840xh1470	615x630xh940	370	83
Koala 370 AF cooling unit on back positive static	K370AFDSDYM1 K370AFDSDZM1	melange grey blue	800x1000xh1310	615x630xh940	370	85
Koala 370 AF cooling unit on top positive ventilated	K370AFTVDYM1 K370AFTVDZM1	melange grey blue	800x840xh1530	615x630xh960	370	95
Koala 370 AF cooling unit on back positive ventilated	K370AFDVDYM1 K370AFDVDZM1	melange grey blue	800x1090xh1310	615x630xh960	370	95
Koala 370 AF cooling unit on top negative ventilated	K370AFTVCYM1 K370AFTVCZM1	melange grey blue	800x840xh1530	615x630xh840	325	95
Koala 370 AF cooling unit on back negative ventilated	K370AFDVCYM1 K370AFDVCZM1	melange grey blue	800x1090xh1310	615x630xh840	325	95
ACCESSORIES						
Label holder	AMC101	trasparent	173xh200	148xh210 -A5-		
Grid	AEA018	stainless steel	650x610xh16			3,85

