















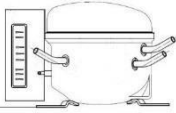







Refrigerated container for the transport of food/pharmaceutical products at a controlled temperature

- Available in versions:
 - AF: temperature adjustment range: from 0°C to +10°C;
 - AFH: with heating kit and temperature adjustment range: from 0°C to +40°.
- Equipped with twelve guides with constant pitch (4 cm), it allows to transport different combinations with GN1 / 1 pans and submultiples.
- Easy to transport by car and easy to handle thanks to the dimensions and weight content.
- Cooling unit is triggered when inner temperature is higher than the temperature set with the programmable digital thermostat. This allows to maintain a constant temperature even in case of very high external temperatures.
- In the AFH versions, the heating unit is triggered when inner temperature is lower than the temperature set with the programmable digital thermostat. This allows to maintain a constant temperature even in case of very low external temperatures.
- Total compliance with the cold chain at all stages of transport.
- It can be transported using conventional vehicles: it allows to simultaneously transport chilled, frozen and ambient temperature products using a single non-insulated vehicle.
- Equipped with a low consumption fridge unit.
- Dual power source: during transport can be connected to the battery (or auxiliary battery) of the vehicle and, at the destination, can be connected to mains power.
- Manufactured using the rotational moulding technology: mono-block container and door (free of sharp edges, joints and welds).
- Fully recyclable at the end of the operating life.

MANUFACTURING MATERIALS

Polyethylene	inner and outer walls of the container and lid; suitable for food contact	Polyurethane	insulating material between the walls of the container and of the lid; free of CFC and HCFC
Silicone	gasket	Polyamide reinforced with fiberglass	hinges, clasp
Galvanized steel	Cooling unit frame	Stainless steel	grip handles

TECHNICAL CHARACTERISTICS

AF version	<ul style="list-style-type: none"> from 0°C to +10°C 	AFH version	<ul style="list-style-type: none"> from 0°C to +40°C
	<p>Equipped with three cables:</p> <p>for power supply to 230Vac 50-60Hz</p>		<p>For power supply to 12Vdc</p> <ul style="list-style-type: none"> with Anderson connectors with Anderson terminal for connection to the Koala and fork terminals for connection to the battery of the vehicle
<p>+/- 0,5 °C</p>	<p>Degree of accuracy in temperature adjustment:</p> <ul style="list-style-type: none"> +/-0,5 °C 		<p>Protection against voltage drops of the vehicle battery, in case of falling below of the limit value of 11V</p>
	<p>Hermetic compressor with electronic control unit for adjustment and control equipped with overvoltage protections</p>	<p>GAS</p>	<p>Coolant gas:</p> <ul style="list-style-type: none"> R134a
	<p>Cooling unit performance guaranteed for use at ambient temperature:</p> <ul style="list-style-type: none"> from +10°C to +30°C 		<p>Container (insulated case) guaranteed for use:</p> <ul style="list-style-type: none"> from -30° to +100°C
	<p>Adjustment and control of the temperature with programmable digital thermostat</p>		<p>Cooling unit equipped with a "roll-bond" static evaporator</p>
	<p>Equipped with 12 guides with 4 pitch. It can carry:</p> <ul style="list-style-type: none"> 2 GN1/1 H200; 3 GN1/1 H150; 4 GN1/1 H100; 6 GN1/1 H65 		<p>Equipped with opening door up to 240 ° and easily removable, to facilitate washing operations</p>
	<p>Easily removable door seal</p>		<p>Integrated stainless steel handles</p>
	<p>Melform closing hook in shockproof material</p>		<p>Equipped with shockproof and hinges, with high resistance to stresses</p>
	<p>Fitted with adjustable venting valve</p>		<p>Monobloc structure, no sharp edges, joints and welds</p>
	<p>Trolley:</p> <ul style="list-style-type: none"> loading capacity 150 Kg 4 castors made of anti tracking rubber and PP; Castor diameter: 125 mm 2 fixed castors; 2 swivelling castors, of which 1 with brake 		<p>Available (on request) USB datalogger to record temperature data during transport</p>
	<p>An optional card label kit allows to easily identifying the content or the routing</p>		<p>Stainless steel GN1/1 grid available upon request</p>
	<p>Insulated with CFC and HCFC-free polyurethane foam</p>		<p>An optional interlocking kit allows securing the Koala 90 to its trolley</p>

TECHNICAL SPECIFICATIONS

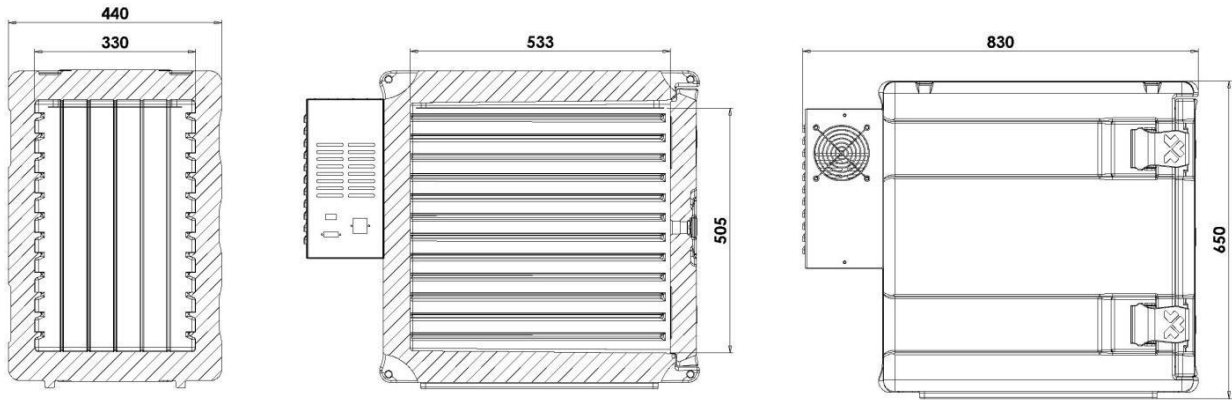

Model with cooling unit on back static K90AFDSDYM0 and K90AFDSDZM0

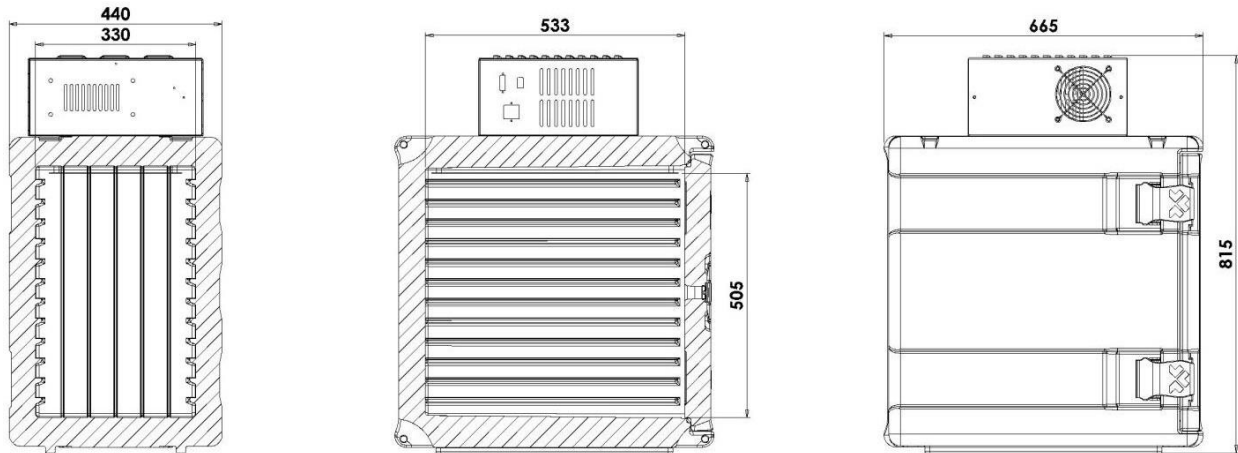

Model with cooling unit on top static K90AFTSDYM0 and K90AFTSDZM0

Model	Code	Nominal absorption	Fuses
AF VERSION			
Koala 90 AF cooling unit on back static from 0°C to +10°C	K90AFDSDYM0	0,35A to 230Vac 7A to 12Vdc	4A for 230Vac 15A for 12Vdc
Koala 90 AF cooling unit on top static from 0°C to +10°C	K90AFTSDYM0	0,35A to 230Vac 7A to 12Vdc	4A for 230Vac 15A for 12Vdc
AFH VERSION (with heating kit)			
Koala 90 AFH cooling unit on back static from 0°C to +40°C	K90AFDSDZM0	0,35A to 230Vac 7A to 12Vdc	4A for 230Vac 15A for 12Vdc
Koala 90 AFH cooling unit on back static from 0°C to +40°C	K90AFTSDZM0	0,35A to 230Vac 7A to 12Vdc	4A for 230Vac 15A for 12Vdc

Model	Code	Colour	External dim. (mm)	Internal dim. (mm)	Capacity l	Weight Kg
Koala 90 AF/AFH cooling unit on back, static	K90AFDSDYMO K90AFDSDZM0	melange grey blue	440x830xh650	330x533xh505	90	27
Koala 90 AF/AFH cooling unit on top, static	K90AFTSDYMO K90AFTSDZM0	melange grey blue	440x665xh815	330x533xh505	90	27
ACCESSORIES						
Grid GN 1/1 in stainless steel	AEA020	stainless steel	530x325xh12			1,3
Trolley for AF12/Koala 90	THS20009	melange grey blue	505x685xh205			6,4
Card label kit	RRI157		100 pcs per kit			
Mono interlocking kit - 2 pieces -	RRI137	stainless steel	2 pcs per kit			0,6



Via Savigliano 34 - 12030 Monasterolo di Savigliano (CN)
 Tel. +39 0172812600 - Fax +39 017285991 - info@melform.com
 GPS: Lat 44.681363 - Long 7.624809

www.melform.com

2893e80b4a2d478fc4897d962bad02c05a4e40d0a8814c87c2c94b98f9532c43